

kl.Pz.Bf.Wg. 1 KIA

(INITIAL PRODUCTION)

Conversion kit for
TRISTAR Pz.Kpfw.IA

1:35
LEADWARRIOR

LW 35004C

WWW.LEADWARRIOR.COM INFO@LEADWARRIOR.COM COPYRIGHT 2003

1 Panzer Division, Germany, 1935

- Lite Gray
- Brown

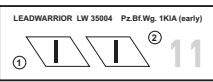
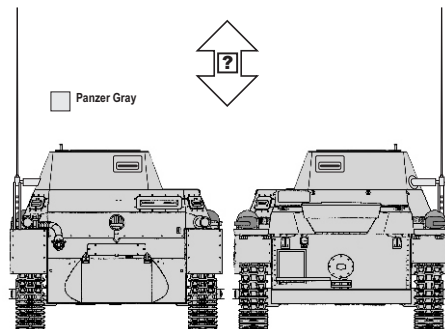
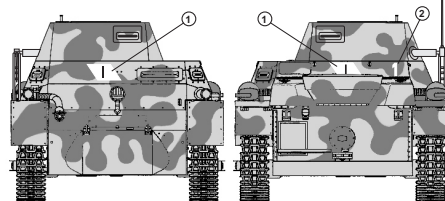
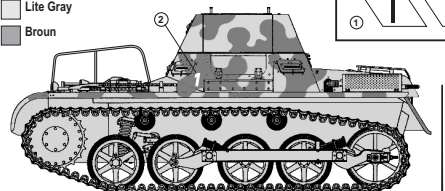

In 1934, when Germany recreated armoured forces in defiance of the Treaty of Versailles, the need in armoured command vehicle had spring up to complete first two Panzer regiments. The first and only German tank of the time, Pz.Kpfw. I, had room for a radio receiver only, and had to be modified to accommodate a transmitter and its operator. The vehicle received designation Kleine Panzerefuhrwagen, or kl.Pz.Bf.Wg I. An additional FuG-2 ultra short wave receiver and 20 watt receiver-transmitter FuG-6 were installed. 184 were made by Daimler-Benz from the end of 1935 to 1937. Most of these vehicles were based on Pz.Kpfw. I Ausf B, and only 6, designated 1 KIA, utilised Ausf A chassis. These very rare machines are known in two variants. The first type of 1 KIA, presented by this kit, had a small rectangular fixed turret in place of linear Pz.Kpfw. I Ausf A turret.

